

DORICA 50CL

Caratteristiche del prodotto

Codice	2962/490
Capacità	500 ml
Imboccatura	BVP 31,5 STD
Colori	
Peso	340 gr
Altezza Totale	265.90 mm
Diametro	61.40 mm
Pallet	2.331 Unitá

VISTA FRONTAL
(FRONT VIEW)

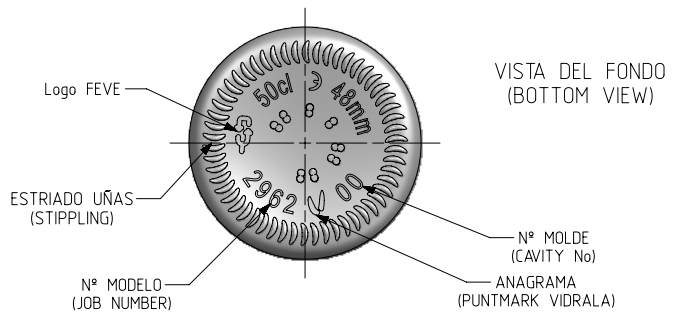
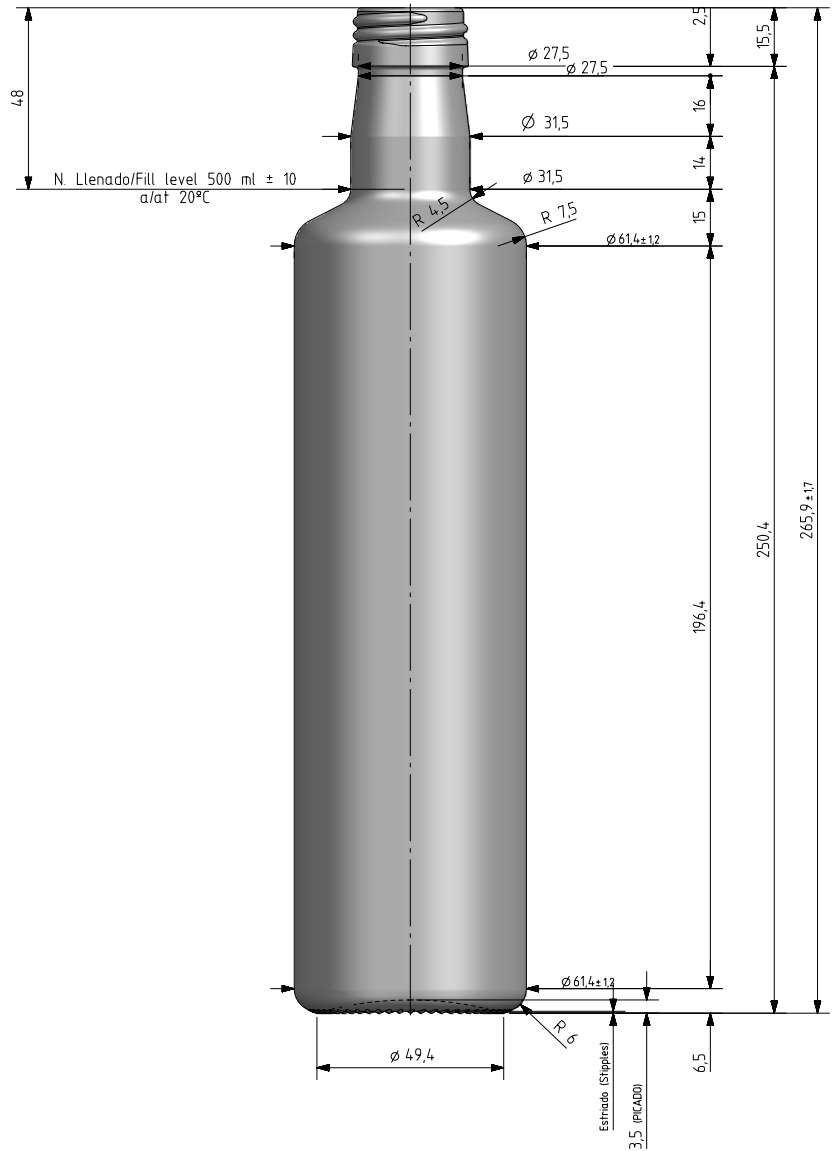

				Capacidad N. llenado / Fillpoint Capacity: 500 ml ± 10 a 48 mm	Cad: 7851-C2.prt Anula/Anuls: 7951-C1
				Capacidad a verter / Brimfull Capacity: 520 ml ± aprox	Fecha / Date: 29-05-24
				Peso aproximado / Weight aprox: 340 g	Dibujado / Des: J. Ochoa
				Cámara de expansión / Vacuity: 4,0 % 20 ml	Escala / Scale: 1:1
				Ángulo de volcado / Tilt angle: 13,5°	Tipo de boca / Finish Type: BVP 31,5 STD EN-15543
				Carbonatación / Gas vol: 0,0 Vol. CO ₂ max	Nº de Plano Drawing Nº 7951-C2 Modelo Code 2962/490
C2	Modificación para nivel de llenado 48	8-04-25	JOJ	Tratamiento térmico / Thermal Treatment: NO	DORICA 50CL
C1	Modificación para llenado a 47mm	22-07-24	JOJ	Resistencia a choque térmico / Thermal Shock max: 42 °C	
Rev.	Modificación / Modification	Fecha / Date	Firma / Sign	Retornable / Returnable	NO



Este plano es propiedad de Vidrala, no puede ser reproducido ni comunicado sin nuestro permiso. / Specification agreements are based on tolerances dimensions only. Do not scale drawing, copyright reserved